



MK Diamond Products, Inc.

www.mkdiamond.com

MK-112 TILE SAW OWNERS MANUAL & OPERATING INSTRUCTIONS



Revision 202	02.2004

Caution: Read all safety and operating instructions before using this equipment. This parts list **MUST** accompany the equipment at all times.



MK Diamond Products, Inc.

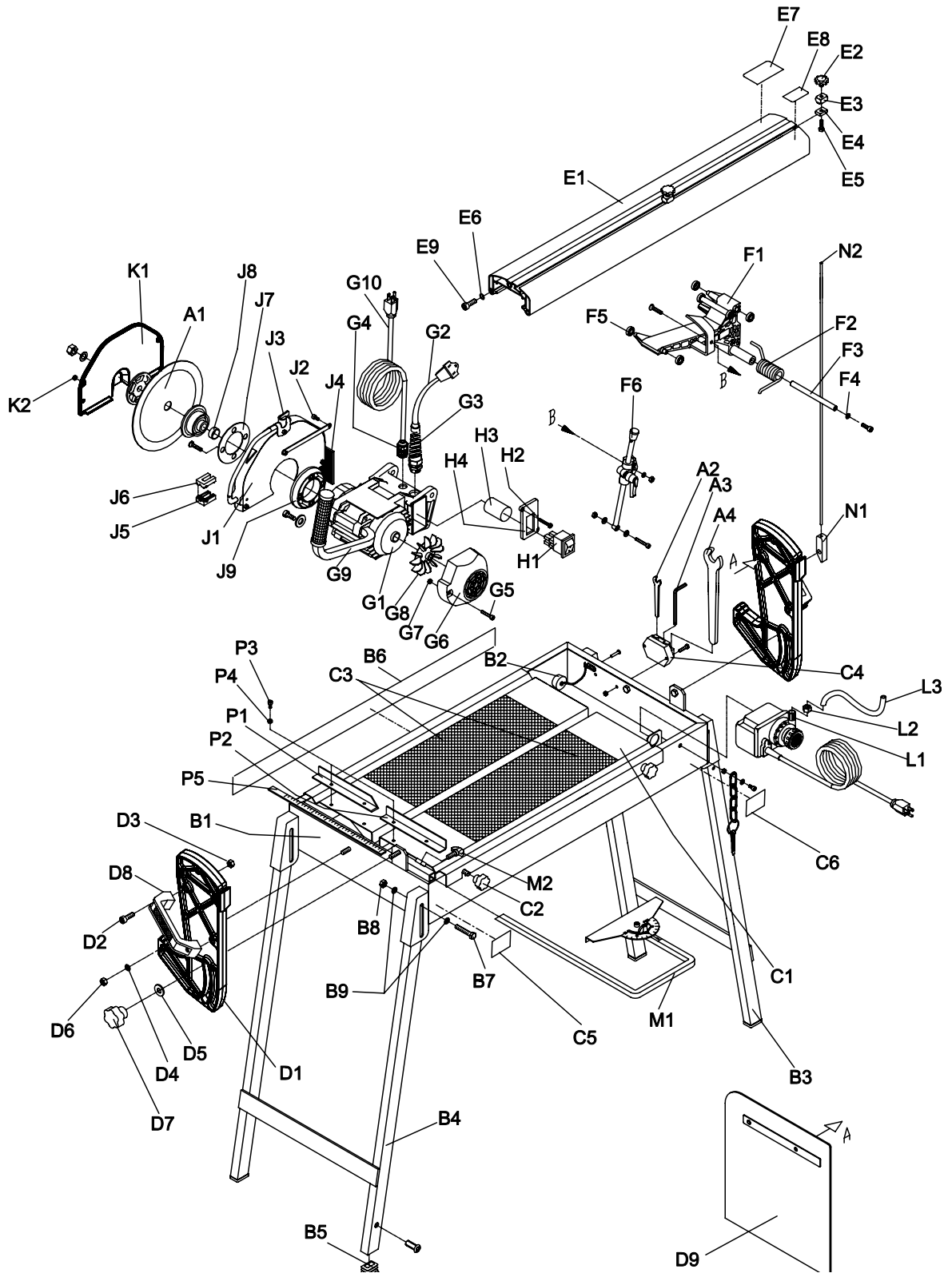

EXPLODED VIEW

PARTS LIST:

Item	Description	Qty	MK Part #
A Assembly, Accessories			
A1	Blade, MK-200, 8x7/8 Arbor	1	137158Y
A2	5mm wrench	1	160529
A3	5mm Allen key	1	159979
A4	19mm wrench	1	160530
A5	Card, MK Warranty Registration (not shown)	1	155037
A6	Manual, MK-112 Owners (not shown)	1	160467
A7	Label, Do Not Return (not shown)	1	157063
B Assembly, Frame/Pan			
B1	Frame / Pan Weldment	1	160531
B2	Plug, Rubber Drain	1	160532
B3	Leg, Stand LT	1	160533
B4	Leg, Stand RT	1	160534
B5	Foot, Rubber	4	160535
B6	Label, MK-112 Title	1	160468
B7	Screw, Hex HD 5/16-18X1-1/2	4	152467
B8	Nut, Hex Nylock	4	158289
B9	Washer, 5/16 SAE Flat	8	151754
C Assembly, Table			
C1	Table, MK 112	2	160536
C2	Knob, MK 112 Table	4	160537
C3	Mats, MK 112 Table	4	160538
C4	Holder, Accessory	1	160539
C5	Label, Serial #, MK-112	1	160469
C6	Label, MK Service Info. 2 1/8 X 1-13/16	1	155038
D Assembly, Pivot Post			
D1	Post, 112 (comp)	2	160466
	Post, 112 (raw)	2	160417
D2	Screw, Soc HD Cap M8X1.25X50MM	4	160540
D3	Nut, Hex Flange M8		156624
D4	Washer, 5/16 SAE Flat	2	151754
D5	Washer, Fender 5/16 IDX 1.0 OD	2	151053
D6	Nut, Hex Nylock 5/16-18	2	158289
D7	Knob, 3/16-18 MK Angle Adjustment	2	160541
D8	Handle, MK 112	2	160542
D9	Guard, Large Splash	1	160543
E Assembly, Rail			
E1	Rail, MK 112	1	160544
E2	Knob, MK 112 Cut Length Adjustment	2	160545
E3	Spacer, Length Adjustment	2	160546
E4	Guide, Length Adjustment	2	160547
E5	Screw, Hex HD M6 x 20mm	2	158158
E6	Wawher, Lock Split 5/16	6	151747
E7	Label, Warning, Read Owners	1	155806
E8	Label, Caution, GFCI	1	155678
E9	Screw, Hex HD M6 x 20mm	2	158158

MK-112 PARTS LIST (Cont...)

F	Assembly, MK 112 Cutting Head		
F1	Block, Rail Saw Bearing	1	160548
F2	Spring, Cutting Head	1	160549
F3	Shaft, Cutting Head	1	160550
F4	Washer, 5/16 SAE Flat	2	151754
F5	Bearing, Radial Ball TYPE 608 ABEC-1	6	160551
F6	Rail, Vertical Guide	1	160552
G	Assembly, 115V Motor		
G1	Motor, 115 Volt, 60Hz, 1 hp	1	160553
G2	Power, Water Pump	1	160554
G3	Relief, MK-112 Strain w/Lock Nut	1	160555
G4	Nut, Strain Relief Lock	1	160556
G5	Screw, Soc HD Cap M5 x 25mm	2	160557
G6	Cap, Motor	1	160558
G7	Nut, M5-.8 Hex	4	157405
G8	Fan, Motor	1	160559
G9	Handle, Motor	1	160560
G10	Cord, MK-112 Power	1	160561
H	Assembly, MK 112 Switch		
H1	Switch, MK 112	1	160562
H2	Screw, Pan HD PHIL 4M x 12mm	2	160563
H3	Sleeve, Wire	1	160564
H4	Plate, MK 112 Switch	1	160565
J	Assembly, Inner Blade Guard		
J1	Guard, MK 112 Inner Blade (comp)	1	160566
J2	Screw, Socket Cap M5 X 10mm	1	160567
J3	Valve, Water	1	160568
J4	Guard, Splash	1	160310
J5	Spray, Water, Bottom (Fem)	1	160569
J6	Spray, Water, Top (Male)	1	160570
J7	Spacer, Steel	1	160571
J8	Bushing, Blade Guard	1	160572
J9	Connector, Blade Guard	1	160573
K	Assembly, Blade Guard		
K1	Blade Guard, 112 (comp)	1	160438
	Blade Guard, 112 (raw)	1	160437
K2	Nut, Hex Flange M5	2	160574
L	Assembly, Water Pump		
L1	Pump, Water	1	160575
L2	Adapter, Brass	1	160576
L3	Hose, Vinyl	1	160577
M	Assembly, MK 112, Slide Protractor		
M1	Protractor, MK 112 Sub-assembly	1	160578
M2	Knob, Protractor	1	160579

MK-112 PARTS LIST (Cont...)

N	Assembly, Antenna		
N1	Holder, Antenna	1	160580
N2	Antenna	1	160581
P	Assembly, Back Stop		
P1	Stop, Left	1	160582
P2	Stop, Right	1	160583
P3	Screw, Soc HD Cap M5 x 8mm	5	160584
P4	Nut, Hex Flange M5	4	160585
P5	Ruler, Stop	1	160586
R	Assembly, Side Table		
R1	Table, MK-112 Side	1	160588
R2	Mats, MK-112 Table	3	160538
R3	Stop, Right	2	160583
R3	Screw, Soc HD Cap M5 x 8mm	4	160584
R4	Nut, Hex Flange M5	4	160585
R6	Leg, MK-112 Side Table	1	160589